

Bosch Ignition Setup for Fiat Dino, Ferrari Dino 246 and Lancia Stratos Points Setup Wiring

V 2.2 info@dinoplex.org 01/2009
www.dinoplex.org

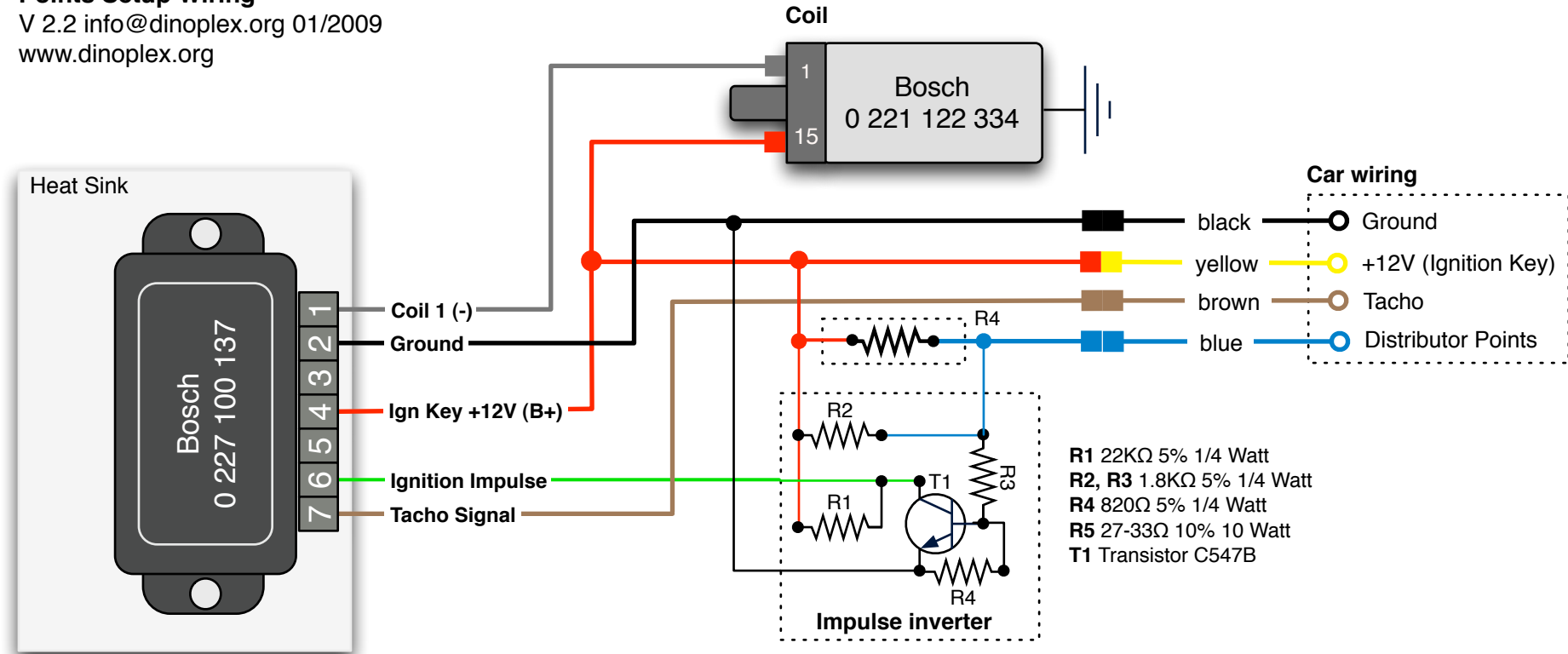

Bosch 0 227 100 137/139 Wiring

- 1 Coil Negative
- 2 Module Ground
- 3 Pulse Gen Ground
- 4 Ignition +12V
- 5 Pulse Gen Supply Voltage
- 6 Pulse Gen Input Signal
- 7 Electronic Tacho Signal

This setup is a replacement for the Dinoplex AEC 103 and is based on a Bosch high power inductive ignition.

The Bosch BIM-137 (0 227 100 137) ignition controller handles power management and dwell control, keeping the temperature of the coil down while maximizing the ignition energy in the full RPM range. Use only the dedicated transistor ignition coil (0 221 122 334) to get the best performance and to avoid defects and overheating. No ballast resistor is required.

The impulse inverter circuit shown above will create a trigger impulse each time the points open. A 27Ω ballast resistor ensures that the points stay clean by running a small current through the contacts. To wire the ignition controller into the car wiring, Bosch offers a plug connector, part # 1 287 013 005. The ignition controller must be mounted on a heat sink (do not forget to apply thermal grease). Bosch also offers a compatible ready made heat sink as part #1 221 040 009.