

# Magneti Marelli Dinoplex AEC 101DA Ferrari Dino 246 Wiring, '69 Europe

V 1.0 12/2010, Copyright www.dinoplex.org, info@dinoplex.org

This wiring diagram applies to the early Ferrari 246GT Dino (L Series)

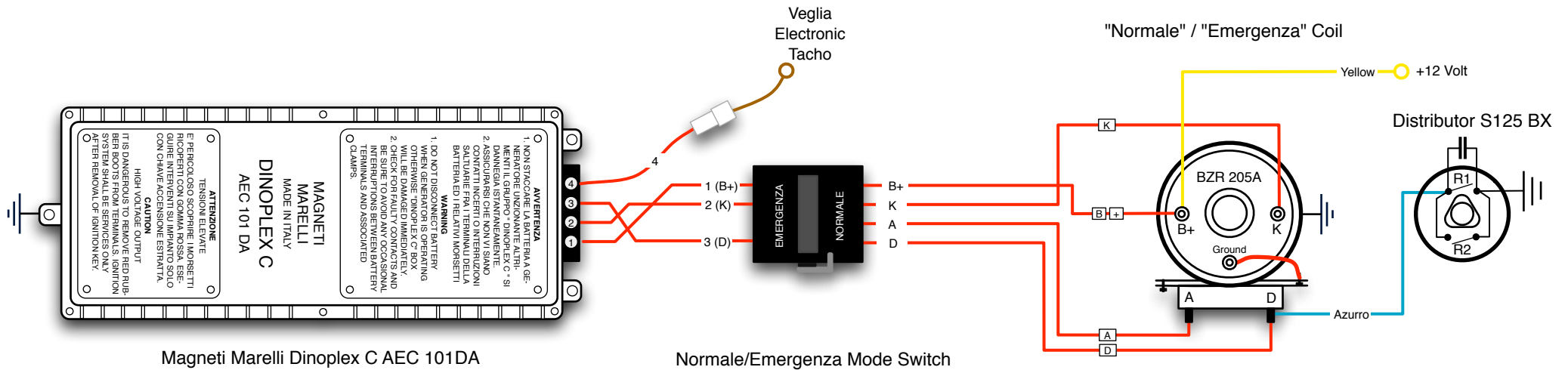

## Dinoplex C AEC101DA Wires to Switch

1. 'B+' +12V from ignition key, red wire
2. 'K' to ignition coil terminal 'K', red wire
3. 'D' from distributor points R1, red wire
4. to Veglia tachometer, red wire

## Dinoplex C AEC101DA Switch to Car

1. 'B+' +12V from ignition key and coil terminal B+, red wire with white wire markers
2. 'K' to ignition coil terminal 'K', red wire with white wire marker
3. 'A' to ballast resistor terminal 'A', red wire with white wire marker
4. 'D' from distributor points R1, red wire with white wire marker