

Magneti Marelli Dinoplex AEC 104B/BK/BW External Wiring
V 1.1 info@dinoplex.org 10/2009, www.dinoplex.org

Magneti Marelli AEC 104B for distributor with points setup

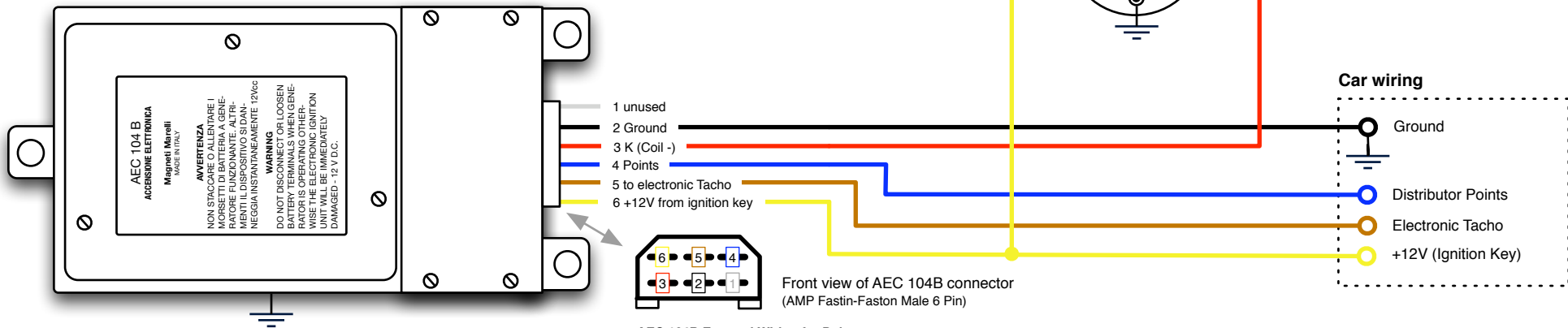

Magneti Marelli AEC 104B for magnetic pickup setups

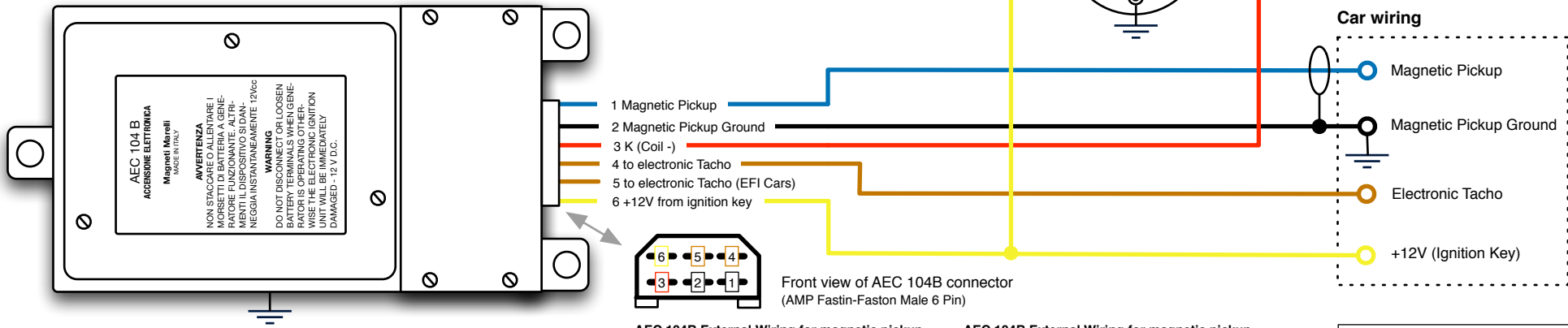

AEC 104B External Wiring for magnetic pickup
 1 Input from magnetic pickup
 2 Ground magnetic pickup (black)
 3 to Coil 'K' (red)
 4 to electronic Tachometer (brown)
 5 to electronic Tachometer (EFI cars)
 6 +12V from ignition key (yellow)

Wire colors are based on Ferrari wiring

AEC 104B External Wiring for magnetic pickup
 1 Input from magnetic pickup (black/blue)
 2 Ground magnetic pickup (black)
 3 to Coil 'K' (black/white)
 4 to electronic Tachometer (brown)
 5 unused
 6 +12V from ignition key (violet/black)

Wire colors are based on Lamborghini wiring

Wiring of the Tach output cable	
Ferrari 365GT4 BB:	Pin 4
Ferrari 512BB:	Pin 4
Ferrari 512BBI:	Pin 5
Ferrari 400i:	Pin 5
Lamborghini Countach QV:	Pin 4
Lamborghini LM002:	Pin 4