

Magneti Marelli Dinoplex AEC 104 B-660 & AEC 104B-780 Magnetic pickup (VR) based setups

V 2.0 10/2009, Copyright www.dinoplex.org, info@dinoplex.org

The AEC 104 B-660 and AEC104B-780 feature a rev limiter and a magnetic (VR) pickup trigger input. The rev limiter in model B-660 is set to 6600 RPM and in B-780 to 7800 RPM.

Magneti Marelli AEC 104B-660/780 for magnetic (VR) pickup based setups

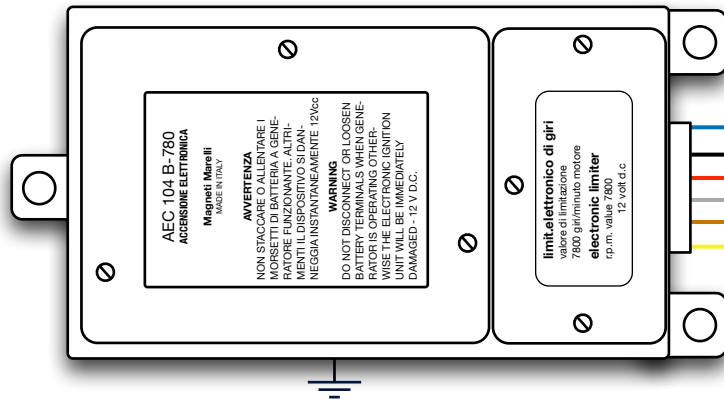

- 1 Magnetic Pickup
- 2 Magnetic Pickup Ground
- 3 K (Coil -)
- 4 unused
- 5 to electronic Tacho
- 6 +12V from ignition key

Magneti Marelli BAE202B Ignition Coil

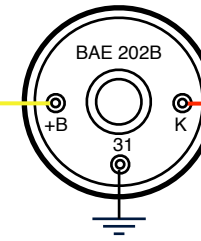

Car wiring

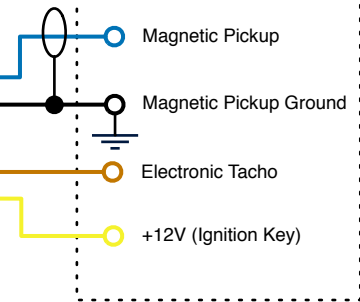

AEC 104B-660/780 connector, Front View
(AMP Fastin-Faston Male 6 Pin)

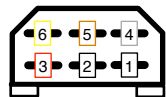

- 1. Input from magnetic pickup
- 2. Ground magnetic pickup (black)
- 3. to Coil 'K' (red)
- 4. unused
- 5. to electronic Tachometer (brown)
- 6. +12V from ignition key (yellow)